

# MUI241XX Micro STEPPER MOTOR CONTROLLER



## General information

MUI241XX are miniature stepper motor controllers with RS232 communication interface. User device can command these controllers through RS232 using ASCII coded instructions with minor or no knowledge about the stepper motor driving. Instructions are simple, intuitive and fault-tolerating. User is not required to have advance knowledge on stepper motor driving. This controllers can be mounted onto MP042/MP057/MP086/MP110 series stepper motor seamlessly using flanges. Thickness of the controller is less than 14 millimeter.

## Mechanical

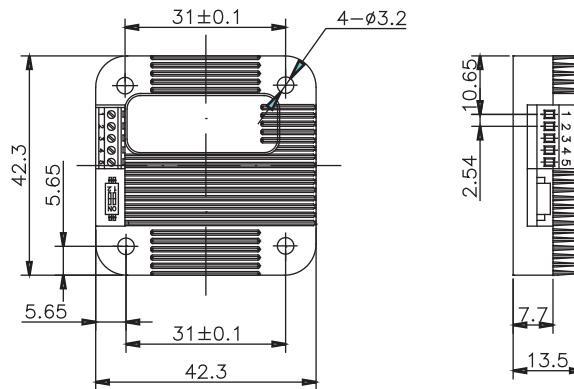

## Specifications

### Characteristics

Supply Voltage	40VDC
Store Temperature	-20°C~+125°C
Working Temperature	-20°C~+125°C

### Communication(Ambient Temperature 25°C)

Communication protocol	RS232
Wiring Method	3-wire:TX、RX、GND
Baud Rate	MAX 115200 bps

### Electrical Characteristics(Ambient Temperature 25°C)

Supply Power Voltage	10V~40VDC
Motor Output Current	Max 2A/4A/8A per phase (Adjustable through RS232 instruction)
Driving Mode	PWM constant current
Stepping Resolution	full-step, half-step,quarter-step,and sixteenth-step
Insulation Resistance	>100MΩ
Dielectric Strength	0.5KV in one minute

# MUI241XX Micro Stepper Motor Controller

## Specifications

### Environment Requirements

Cooling		Free Air
Working Environment	Environment	Avoid dust, oil mist and corrosive gases
	Temperature	-20°C ~ +85°C
	Humidity	<80%RH, n condensation, no frosting
	Vibration	3G Max
Storage Temperature		-40°C ~ +125°C
Size		42.3mm×42.3mm×13.5
Weight		0.1Kg

## Typical Application

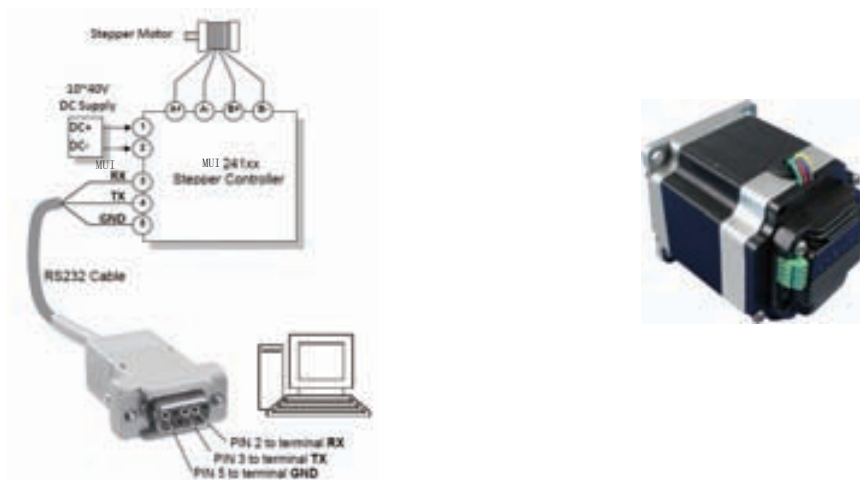

## Example

MOTOR PARAMETERS			
	Units	Tolerance	Value
Step Angle	°		1.8
Accuracy			±5%
Holding Torque	Ncm		90
Rated Current	A/ph		2
Phase Resistance	ohms	±10%	1.8
Phase Inductance	MH	±20%	2.5
Detent Torque	Ncm	Max	4
Rotor Inertia(Ja)	g.cm <sup>2</sup>		300
Weight	g		600

